

INTRODUCTIONS

1. Power module incorporates an IEC connector, a fuse holder with optional power on/off switch and voltage selector switch, plus an EMI filter all-in-one single, easy-to-install unit.
2. Fuse holder designed for one IEC 5x20mm fuse. Safety interlock prevents fuse removal with line plug inserted (Use only with 250V fuse).
3. All part numbers are UL recognized, CSA certified and VDE approved.

SPECIFICATIONS

1. Maximum leakage current each
line-to-ground @ 115VAC 60Hz: 0.25mA
@ 250VAC 50Hz: 0.45mA
2. Hipot rating (one minute)
line-to-ground: 2250VDC
line-to-line: 1450VDC
3. Operating frequency: 50/60Hz
4. Rated voltage: 115/250VAC

MINIMUM INSERTION LOSS IN dB

COMMON MODE (L-G) IN 50 OHM SYSTEM						
CURRENT RATING	FREQUENCY-MHz					
	.15	.50	1.0	5.0	10	30
3A	30	35	40	35	35	35
6A	16	25	30	42	45	40
DIFFERENTIAL MODE (L-L) IN 50 OHM SYSTEM						
3A	10	40	45	45	45	35
6A	6	25	30	42	45	40

TYPE & RATED CURRENT

DELTA PART NO.	AK1	AK2	AK2D	AK3	AK3D	AK4	AK5
RATED CURRENT	115VAC	6A	6A	6A	6A	6A	6A
	250VAC	6A	6A	4A	5A	4A	6A
IEC CONNECTOR	△	△	△	△	△	△	△
FUSE HOLDER	△	△	△	△	△	△	△
POWER SWITCH	-	SP ¹	DP ²	SP ¹	DP ²	-	-
VOLTAGE SELECTOR SW	-	-	-	REAR ³	REAR ³	REAR ³	FRONT ⁴
ELECTRICAL SCHEMATIC	FIG. A	FIG. A	FIG. B	FIG. A	FIG. B	FIG. A	FIG. C

1. Single-pole UL, CSA & VDE approved
Current rating: UL & CSA-6A both at 125VAC & 250VAC;
VDE-6A at 250VAC.
Electrical lifetime: 50,000 cycles.
Maximum inrush current: 70A.
2. Double-pole UL CSA & VDE approved
Current rating: UL & CSA-6A at 125VAC, 4A at 250VAC;
VDE-4A at 250VAC.
Electrical lifetime: 10,000 cycles.
Maximum inrush current: 50A.
3. Voltage selector SW -UL, CSA & VDE approved
Current rating: 10A at 125VAC; 5A at 250VAC.
4. Voltage selector SW -UL, CSA & VDE approved
Current rating: UL & CSA-6A both at 125VAC & 250VAC;
VDE-6A at 250VAC.

ELECTRICAL SCHEMATIC

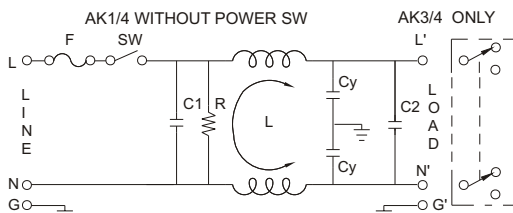

FIG. A

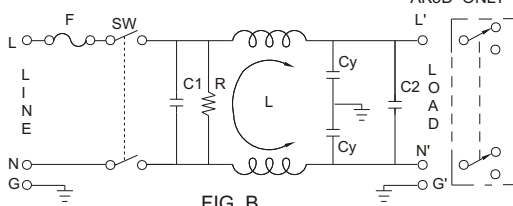

FIG. B

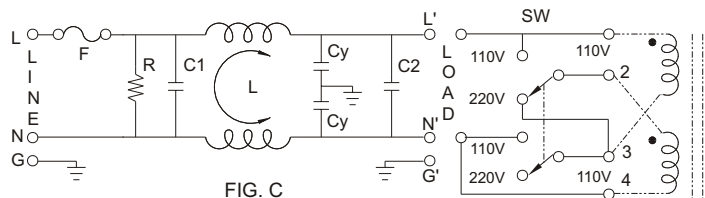
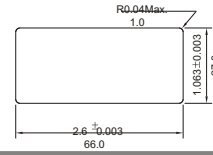

FIG. C

For transformers with two separate windings

COMPONENT VALUE:

6A:	3A:
R: 2.2MΩ	R: 1MΩ
C1: 0.1uF	C1: 0.1uF
C2: 0.1uF	C2: 0.1uF
Cy: 3300pF	Cy: 2200pF
L: 1.3mH	L: 14mH



- Suggested thickness of mounting panel is from 0.04 to 0.07 inch
- Suggested mounting cutout

MECHANICAL CONSTRUCTION



AK5

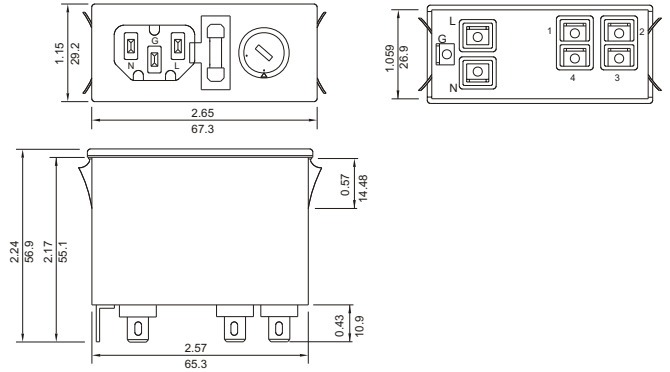

AK2,AK2D

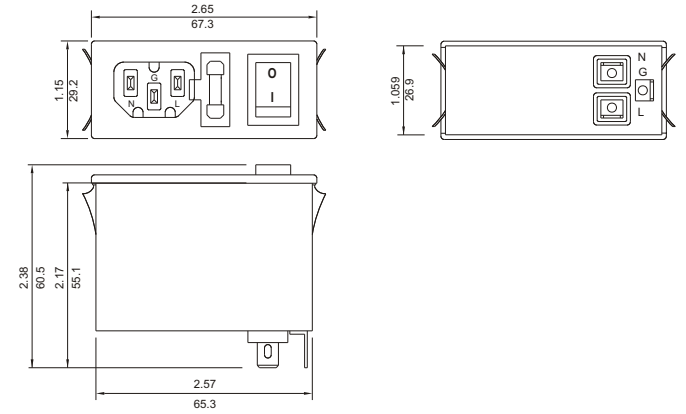

AK3,AK3D
AK4 (without power switch)

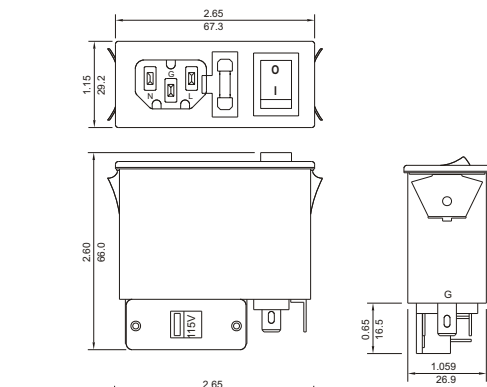

AK1

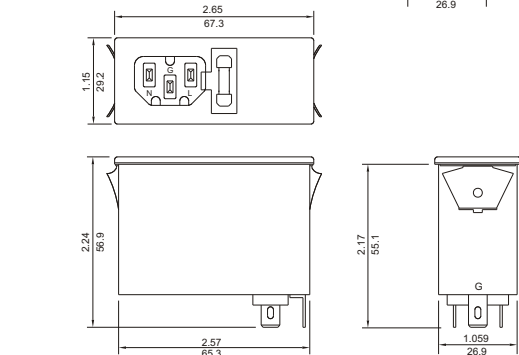

UNIT: INCH
mm